

SECTION **FSU**
FRONT SUSPENSION

A
B
C
D
E
F
G
H
I
J
K
L
M
N
O
P

FSU

CONTENTS

SYMPTOM DIAGNOSIS	2	TRANSVERSE LINK	10
NOISE, VIBRATION AND HARSHNESS (NVH) TROUBLESHOOTING	2	Removal and Installation	10
NVH Troubleshooting Chart	2	FRONT STABILIZER	11
PRECAUTION	3	Removal and Installation	11
PRECAUTIONS	3	STEERING KNUCKLE	12
Precaution for Supplemental Restraint System (SRS) "AIR BAG" and "SEAT BELT PRE-TENSIONER"	3	Removal and Installation	12
Service Notice or Precautions	3	UNIT REMOVAL AND INSTALLATION	13
PREPARATION	4	FRONT SUSPENSION ASSEMBLY	13
PREPARATION	4	Exploded View	13
Special Service Tool	4	Removal and Installation	14
Commercial Service Tool	5	UNIT DISASSEMBLY AND ASSEMBLY ...	15
PERIODIC MAINTENANCE	6	FRONT COIL SPRING AND STRUT	15
FRONT SUSPENSION ASSEMBLY	6	Disassembly and Assembly	15
Inspection and Adjustment	6	Inspection	16
REMOVAL AND INSTALLATION	8	SERVICE DATA AND SPECIFICATIONS (SDS)	17
FRONT COIL SPRING AND STRUT	8	SERVICE DATA AND SPECIFICATIONS (SDS)	17
Removal and Installation	8	Wheel Alignment (Unladen*)	17
Disposal	8	Ball Joint	17
		Wheelarch Height (Unladen*1)	18

NOISE, VIBRATION AND HARSHNESS (NVH) TROUBLESHOOTING

< SYMPTOM DIAGNOSIS >

SYMPTOM DIAGNOSIS

NOISE, VIBRATION AND HARSHNESS (NVH) TROUBLESHOOTING

NVH Troubleshooting Chart

INFOID:000000006236726

Use the chart below to help you find the cause of the symptom. If necessary, repair or replace these parts.

Reference page		FSU-13	FSU-16	—	—	—	FSU-13	FSU-6	FSU-6	WT-55, "NVH Troubleshooting Chart"	WT-55, "NVH Troubleshooting Chart"	FAX-2, "NVH Troubleshooting Chart"	BR-6, "NVH Troubleshooting Chart"	ST-8, "NVH Troubleshooting Chart"
Possible cause and SUSPECTED PARTS		Improper installation, looseness	Shock absorber deformation, damage or deflection	Bushing or mounting deterioration	Parts interference	Spring fatigue	Suspension looseness	Incorrect wheel alignment	Stabilizer bar fatigue	TIRES	ROAD WHEEL	DRIVE SHAFT AND WHEEL HUB	BRAKES	STEERING
Symptom	Noise	x	x	x	x	x	x			x	x	x	x	x
	Shake	x	x	x	x		x			x	x	x	x	x
	Vibration	x	x	x	x	x				x		x		x
	Shimmy	x	x	x	x			x		x	x		x	x
	Shudder	x	x	x						x	x		x	x
	Poor quality ride or handling	x	x	x	x	x		x	x	x	x			

x: Applicable

PRECAUTIONS

< PRECAUTION >

PRECAUTION

PRECAUTIONS

Precaution for Supplemental Restraint System (SRS) "AIR BAG" and "SEAT BELT PRE-TENSIONER"

INFOID:000000006236727

The Supplemental Restraint System such as "AIR BAG" and "SEAT BELT PRE-TENSIONER", used along with a front seat belt, helps to reduce the risk or severity of injury to the driver and front passenger for certain types of collision. This system includes seat belt switch inputs and dual stage front air bag modules. The SRS system uses the seat belt switches to determine the front air bag deployment, and may only deploy one front air bag, depending on the severity of a collision and whether the front occupants are belted or unbelted. Information necessary to service the system safely is included in the SR and SB section of this Service Manual.

WARNING:

- To avoid rendering the SRS inoperative, which could increase the risk of personal injury or death in the event of a collision which would result in air bag inflation, all maintenance must be performed by an authorized NISSAN/INFINITI dealer.
- Improper maintenance, including incorrect removal and installation of the SRS, can lead to personal injury caused by unintentional activation of the system. For removal of Spiral Cable and Air Bag Module, see the SR section.
- Do not use electrical test equipment on any circuit related to the SRS unless instructed to in this Service Manual. SRS wiring harnesses can be identified by yellow and/or orange harnesses or harness connectors.

PRECAUTIONS WHEN USING POWER TOOLS (AIR OR ELECTRIC) AND HAMMERS

WARNING:

- When working near the Airbag Diagnosis Sensor Unit or other Airbag System sensors with the Ignition ON or engine running, DO NOT use air or electric power tools or strike near the sensor(s) with a hammer. Heavy vibration could activate the sensor(s) and deploy the air bag(s), possibly causing serious injury.
- When using air or electric power tools or hammers, always switch the Ignition OFF, disconnect the battery, and wait at least 3 minutes before performing any service.

Service Notice or Precautions

INFOID:000000006236729

- When installing rubber bushings, the final tightening must be carried out under unladen conditions with tires on ground. Oil might shorten the life of rubber bushings. Be sure to wipe off any spilled oil.
- Unladen conditions mean that fuel, engine coolant and lubricant are full. Spare tire, jack, hand tools and mats are in designated positions.
- After servicing suspension parts, be sure to check wheel alignment.
- Self-lock nuts are not reusable. Always use new ones when installing. Since new self-lock nuts are pre-oiled, tighten as they are.

A
B
C
D
FSU
F
G
H
I
J
K
L
M
N
O
P

PREPARATION

< PREPARATION >

PREPARATION

PREPARATION

Special Service Tool

INFOID:000000006236730

The actual shapes of the Kent-Moore tools may differ from those of special service tools illustrated here.

Tool number (Kent-Moore No.) Tool name	Description
HT7252000 (J-25730-B) Ball joint remover	Removing tie-rod outer and lower ball joint
— (J-44372) Spring gauge	Measuring steering wheel turning force, rack sliding force and ball joint swinging force
— (J-49286) Drift and Pull gauge	Measuring drift and pull
KV991040S1 (—) CCK gauge attachment <ol style="list-style-type: none"> 1. KV99104020 Adapter A 2. KV99104030 Adapter B 3. KV99104040 Adapter C 4. KV99104050 Adapter D 5. KV99104060 Plate 6. KV99104070 Guide bolt 7. KV99104080 Spring 8. KV99104090 Center plate 	Measuring wheel alignment
ST35652000 (—) Strut attachment	Disassembling and assembling strut

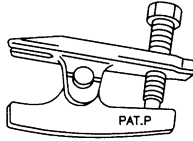

S-NT146

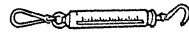

LST024

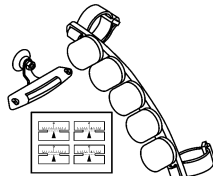

AWEIA0156ZZ

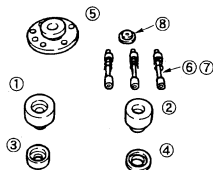

ZZA1167D

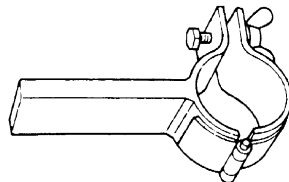



ZZA0807D

PREPARATION

< PREPARATION >

Commercial Service Tool

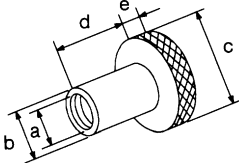
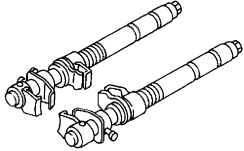
INFOID:000000006236731

Tool name	Description
<p>Power tool</p>  <p>PIIB1407E</p>	<p>Loosening bolts, screws and nuts</p>
<p>Attachment wheel alignment</p> <p>a: screw M24 x 1.5 pitch b: 35 mm (1.38 in) dia. c: 65 mm (2.56 in) dia. d: 56 mm (2.20 in) dia. e: 12 mm (0.47 in) dia.</p>  <p>NT148</p>	<p>Measuring wheel alignment</p>
<p>Spring compressor</p>  <p>NT717</p>	<p>Removing and installing coil spring</p>
<p>Engine slinger</p>  <p>LEIA0062E</p>	<p>Removing and installing suspension member with VQ35DE and CVT</p>

A
B
C
D
FSU
F
G
H
I
J
K
L
M
N
O
P

FRONT SUSPENSION ASSEMBLY

< PERIODIC MAINTENANCE >

PERIODIC MAINTENANCE

FRONT SUSPENSION ASSEMBLY

Inspection and Adjustment

INFOID:000000006236732

INSPECTION

Make sure the mounting conditions (looseness, backlash) of each component and component conditions (wear, damage) are normal.

LOWER BALL JOINT END PLAY

1. Set front wheels in a straight-ahead position. Do not depress brake pedal.
2. Place an iron bar or similar tool between upper link and steering knuckle.
3. Measure axial end play by prying it up and down. Refer to [FSU-17, "Ball Joint"](#).

CAUTION:

Be careful not to damage ball joint boot. Do not damage the installation position by applying excessive force.

SHOCK ABSORBER

Check for oil leakage, damage and replace if malfunction is detected.

WHEEL ALIGNMENT

Description

Measure wheel alignment under unladen conditions.

NOTE:

"Unladen conditions" means that fuel, engine coolant, and lubricant are full. Spare tire, jack, hand tools and mats are in designated positions.

General Information and Recommendations

- A four-wheel thrust alignment should be performed.
- This type of alignment is recommended for any NISSAN vehicle.
- The four-wheel "thrust" process helps ensure that the vehicle is properly aligned and the steering wheel is centered.
- The alignment rack itself should be capable of accepting any NISSAN vehicle.
- The rack should be checked to ensure that it is level.
- Make sure the machine is properly calibrated.
- Your alignment equipment should be regularly calibrated in order to give correct information.
- Check with the manufacturer of your specific equipment for their recommended Service/Calibration Schedule.

Preliminary Check

Check the following:

1. Tires for improper air pressure and wear.
2. Road wheels for runout. Refer to [WT-64, "Road Wheel"](#).
3. Wheel bearing axial end play. Refer to [FAX-26, "Wheel Bearing"](#).
4. Transverse link ball joint axial end play. Refer to [FSU-10, "Removal and Installation"](#).
5. Shock absorber operation.
6. Each mounting part of axle and suspension for looseness and deformation.
7. Each of suspension member, shock absorber, upper link and transverse link for cracks, deformation and other damage.
8. Vehicle height (posture).

Alignment Process

IMPORTANT:

Use only the alignment specifications listed in this Service Manual. Refer to [FSU-17, "Wheel Alignment \(Unladen*\)"](#).

- When displaying the alignment settings, many alignment machines use "indicators" **Do not use these indicators.**: (Green/red, plus or minus, Go/No Go).

FRONT SUSPENSION ASSEMBLY

< PERIODIC MAINTENANCE >

- The alignment specifications programmed into your machine that operate these indicators may not be correct.
- This may result in an ERROR.
- Most camera-type alignment machines are equipped with both "Rolling Compensation" method and optional "Jacking Compensation" method to "compensate" the alignment targets or head units. "Rolling Compensation" is the preferred method.
- If using the "Rolling Compensation" method, after installing the alignment targets or head units, push or pull on the rear wheel to move the vehicle. Do not push or pull on the vehicle body.
- If using the "Jacking Compensation" method, after installing the alignment targets or head units, raise the vehicle and rotate the wheels 1/2 turn both ways.

A
B
C
D

NOTE:

- Do not use the "Rolling Compensation" method if you are using sensor-type alignment equipment.
- Follow all instructions for the alignment machine you are using for more information.

ADJUSTMENT

Camber, Caster and Kingpin Inclination Angles

CAUTION:

Camber, caster, kingpin inclination angles cannot be adjusted.

FSU

F
G
H
I
J
K
L
M
N
O
P

FRONT COIL SPRING AND STRUT

< REMOVAL AND INSTALLATION >

REMOVAL AND INSTALLATION

FRONT COIL SPRING AND STRUT

Removal and Installation

INFOID:000000006236733

REMOVAL

1. Remove tire using power tool.
2. Remove wheel sensor electrical harness from strut. Refer to [BRC-104, "Removal and Installation"](#).
3. Remove brake hose lock plate.
4. Remove steering knuckle to strut bolts and nuts. Refer to [FSU-13, "Exploded View"](#).
5. Remove bolt on strut tower bar, then bolts on strut tower and remove strut from vehicle.

INSPECTION AFTER REMOVAL

Check the strut for any oil leakage or other damage and replace as necessary.

INSTALLATION

Installation is in the reverse order of removal.

- Refer to [FSU-13, "Exploded View"](#) for tightening torque.
- Be sure tab (A) on strut mount insulator is positioned as shown.

A : tab
← : Vehicle front

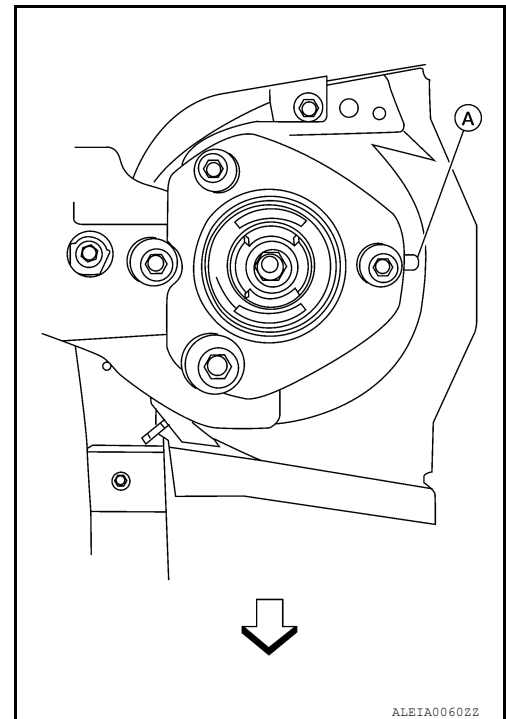

Disposal

INFOID:000000006236734

1. Set strut assembly horizontally with the piston rod fully extended.
2. Drill 2 – 3 mm (0.08 – 0.12 in) hole at the position (●) from top as shown in the figure to release gas gradually.

CAUTION:

- Wear eye protection (safety glasses).
- Wear gloves.
- Be careful with metal chips or oil blown out by the compressed gas.

NOTE:

- Drill vertically in this direction (↓).
- Directly to the outer tube avoiding brackets.
- The gas is clear, colorless, odorless, and harmless.

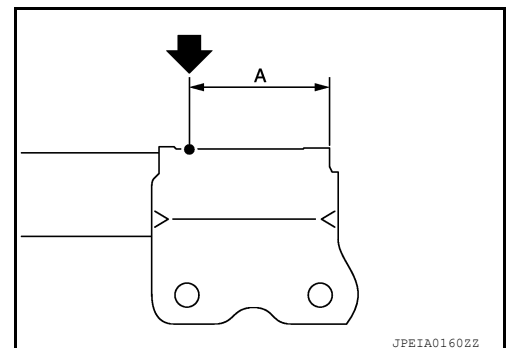

FRONT COIL SPRING AND STRUT

< REMOVAL AND INSTALLATION >

A : 20 – 30 mm (0.79 – 1.18 in)

3. Position the drilled hole downward and drain oil by moving the piston rod several times.

CAUTION:

Dispose of drained oil according to the law and local regulations.

A

B

C

D

FSU

F

G

H

I

J

K

L

M

N

O

P

TRANSVERSE LINK

< REMOVAL AND INSTALLATION >

TRANSVERSE LINK

Removal and Installation

INFOID:000000006236735

REMOVAL

1. Remove tire using power tool.
2. Remove steering knuckle from transverse link using Tool. Refer to [FSU-13, "Exploded View"](#).

Tool number : HT7252000 (J-25730-B)

3. Remove mounting nuts and washers on lower portion of stabilizer connecting rod.
4. Slightly loosen transverse link mounting bolts.
5. Remove transverse link bolts and nuts, and remove transverse link from suspension member.

INSPECTION AFTER REMOVAL

Visual Inspection

Check transverse link and bushing for deformation, cracks, and other damage. Replace the entire transverse link assembly if cracks, deformation or any other damage is found.

Ball Joint Inspection

CAUTION:

Before measurement, move the ball joint at least ten times by hand to check for smooth movement.

Swing Torque Inspection

- Hook Tool at cutout on ball stud. Confirm Tool measurement value is within specifications when ball stud begins moving.

Tool number : — (J-44372)

Swing torque : Refer to [FSU-17, "Ball Joint"](#).

Measurement on spring balance : Refer to [FSU-17, "Ball Joint"](#).

- If the value is outside the standard, replace transverse link.

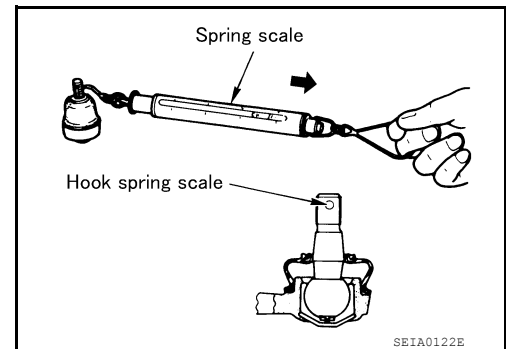

Axial Endplay Inspection

- Move tip of ball joint in axial direction to check for looseness.

Axial endplay : Refer to [FSU-17, "Ball Joint"](#).

- If any looseness is noted, replace transverse link.

INSTALLATION

Installation is in the reverse order of removal.

- Refer to [FSU-13, "Exploded View"](#) for tightening torque.
- Tighten transverse link bolts with vehicle unladen and all four tires on flat, level ground.
- After installation, check wheel alignment. Refer to [FSU-6, "Inspection and Adjustment"](#).

FRONT STABILIZER

< REMOVAL AND INSTALLATION >

FRONT STABILIZER

Removal and Installation

INFOID:000000006236736

REMOVAL

1. Remove steering gear and linkage. Refer to [ST-26. "Removal and Installation"](#).
2. Remove nuts on upper portion of stabilizer connecting rod.

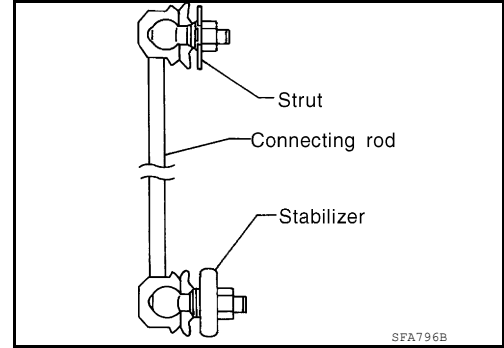

3. Remove stabilizer clamp bolts.
4. Remove stabilizer from the vehicle.

INSPECTION AFTER REMOVAL

Check stabilizer, connecting rod, bushing and clamp for deformation, cracks and damage, and replace if necessary.

INSTALLATION

Installation is in the reverse order of removal. Refer to [FSU-13. "Exploded View"](#).

- When installing stabilizer, make sure that notch (A) in stabilizer clips face front.
- Make sure the slit (B) in surface of stabilizer bushings face rear.
- ← : Front.

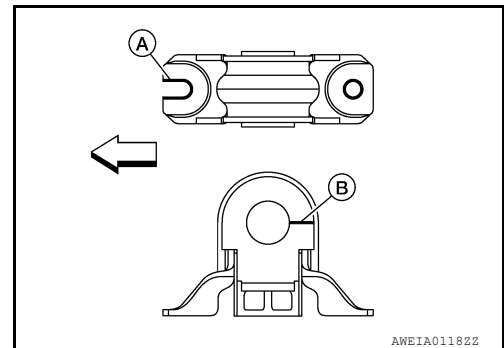

- Stabilizer uses pillow ball type connecting rod. Position ball joint with case on pillow ball head parallel to stabilizer.

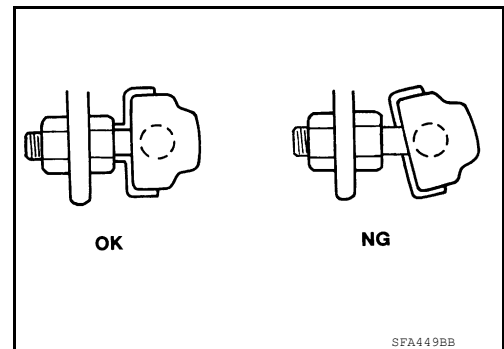

STEERING KNUCKLE

< REMOVAL AND INSTALLATION >

STEERING KNUCKLE

Removal and Installation

INFOID:000000006236737

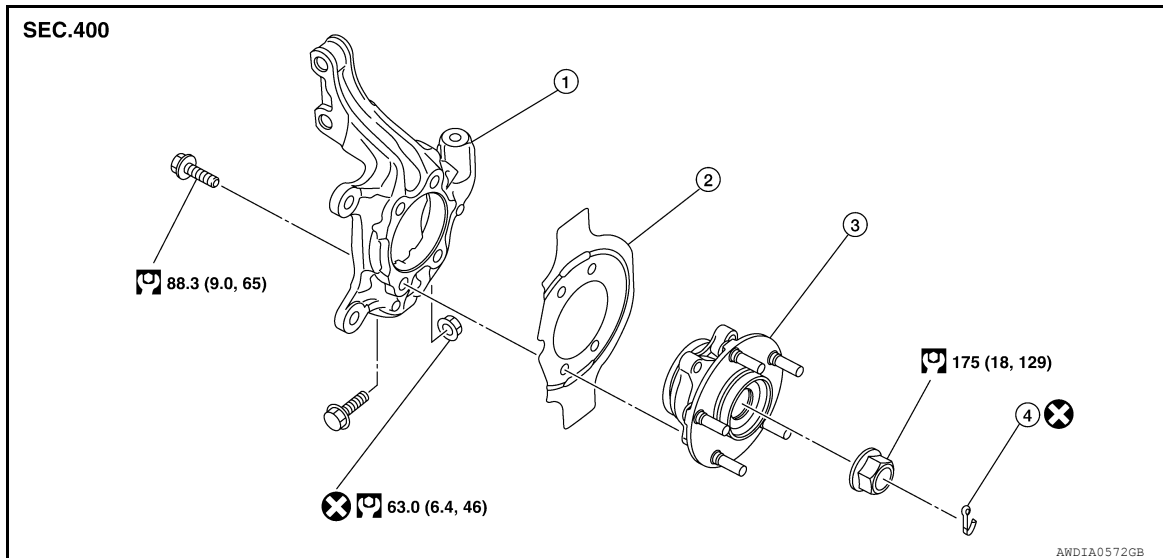

1. Steering knuckle
2. Splash guard
3. Wheel hub and bearing assembly
4. Cotter pin

REMOVAL

1. Remove front wheel hub and bearing assembly. Refer to [FAX-7, "Removal and Installation"](#).
2. Remove steering linkage from steering knuckle. Refer to [ST-26, "Removal and Installation"](#).
3. Remove steering knuckle lower pinch bolt.
4. Remove steering knuckle to strut bolts, then remove steering knuckle. Refer to [FSU-13, "Exploded View"](#).

INSPECTION AFTER REMOVAL

Check for deformity, cracks and damage on each part, replace if necessary.

INSTALLATION

Installation is in the reverse order of removal.

CAUTION:

Do not reuse non-reusable parts.

FRONT SUSPENSION ASSEMBLY

< UNIT REMOVAL AND INSTALLATION >

UNIT REMOVAL AND INSTALLATION

FRONT SUSPENSION ASSEMBLY

Exploded View

INFOID:000000006236738

SEC. 400 • 401 • 406

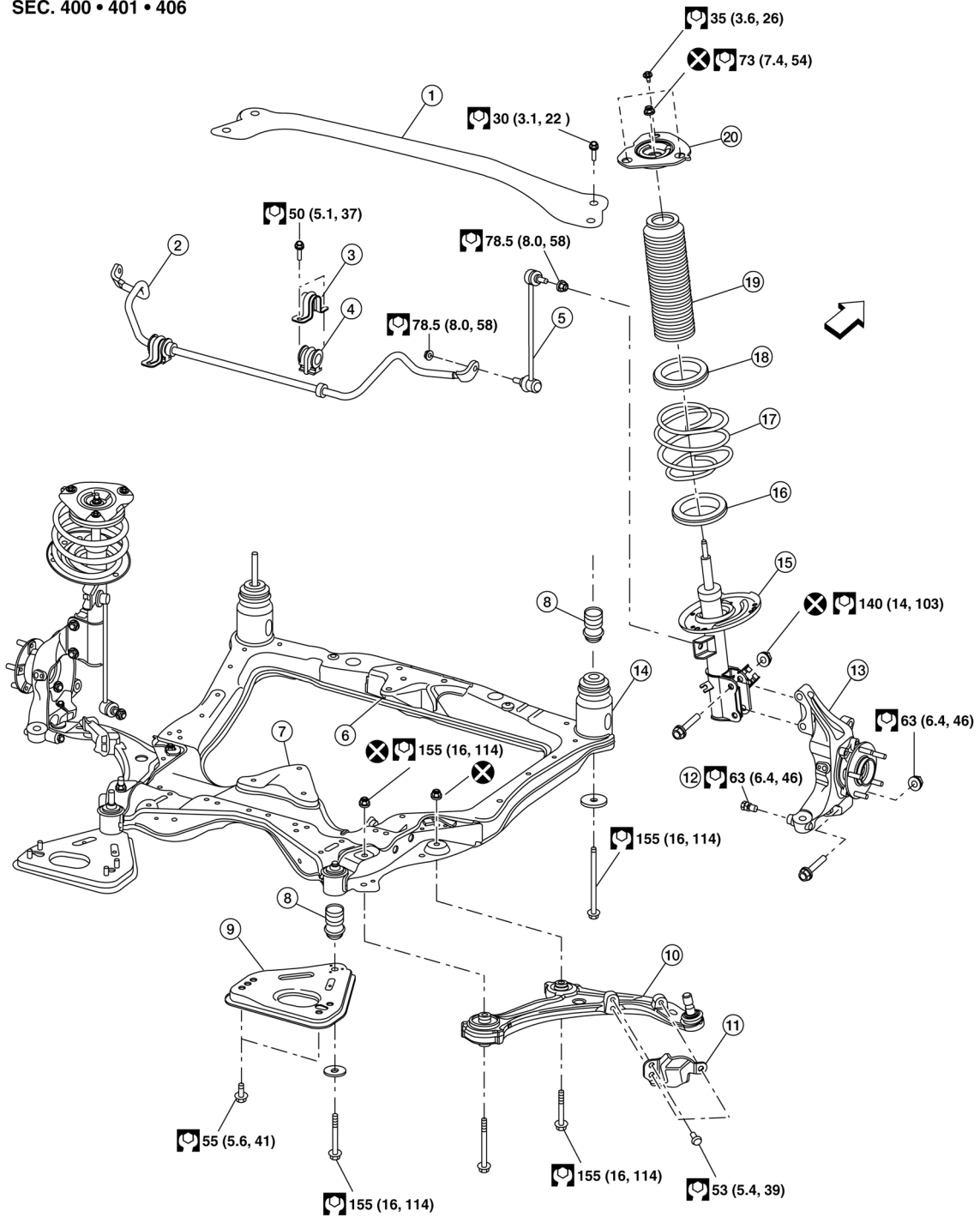

A
B
C
D
F
G
H
I
J
K
L
M
N
O
P

FSU

AWEIA0181GB

FRONT SUSPENSION ASSEMBLY

< UNIT REMOVAL AND INSTALLATION >

- | | | |
|------------------------------|--------------------------------|---------------------------------------|
| 1. Strut tower bar | 2. Stabilizer bar | 3. Stabilizer clamp |
| 4. Stabilizer bushing | 5. Connecting rod | 6. Front mount bracket |
| 7. Rear mount bracket | 8. Suspension member insulator | 9. Member pin stay |
| 10. Transverse link | 11. Steering stop plate | 12. Steering stop |
| 13. Steering knuckle | 14. Front suspension member | 15. Strut |
| 16. Lower rubber seat | 17. Coil spring | 18. Spring upper seat / strut bearing |
| 19. Dust cover/jounce bumper | 20. Strut mount insulator | ⇐ Front |

Removal and Installation

INFOID:000000006236739

REMOVAL

- Engine, transmission and suspension member must be removed as an assembly. Refer to [EM-96, "Removal and Installation"](#).
- Once removed as an assembly, lift engine and transmission off suspension member using suitable tool.

INSTALLATION

Installation is in the reverse order of removal.

- Refer to [FSU-13, "Exploded View"](#) for tightening torque.
- After installation, perform final tightening of each part under unladen conditions with tires on ground. Check wheel alignment. Refer to [FSU-6, "Inspection and Adjustment"](#).

FRONT COIL SPRING AND STRUT

< UNIT DISASSEMBLY AND ASSEMBLY >

UNIT DISASSEMBLY AND ASSEMBLY

FRONT COIL SPRING AND STRUT

Disassembly and Assembly

INFOID:000000006236740

DISASSEMBLY

1. Install Tool (A) to strut and secure it in a vise.

Tool number : ST35652000 (—)

CAUTION:

When installing Tool, wrap a shop cloth around strut to protect it from damage.

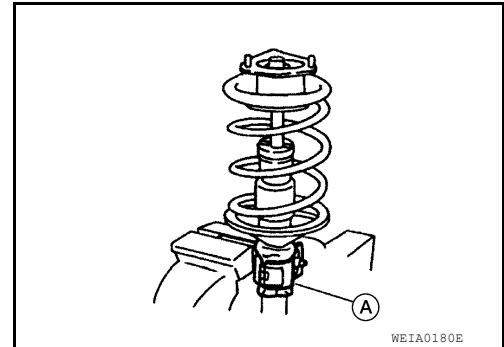

2. Slightly loosen piston rod lock nut.

WARNING:

Do not remove piston rod lock nut completely. If it is removed completely, the coil spring can jump out and may cause serious damage or injury.

3. Compress coil spring using a commercially available spring compressor.

WARNING:

Make sure that the pawls of the two spring compressors are firmly hooked on the spring. The spring compressors must be tightened alternately so as not to tilt the spring.

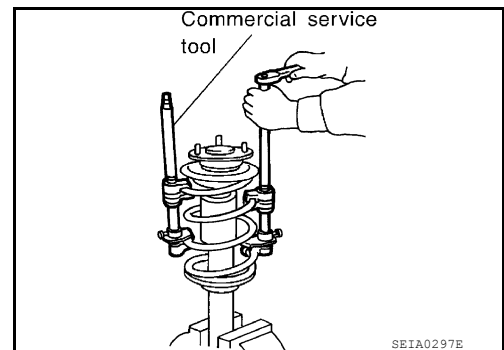

4. Making sure coil spring is free between upper and lower seats, then remove piston rod lock nut.
5. Remove small parts on strut.
 - Strut mount insulator, spring upper seat/strut bearing. Then remove coil spring.
6. Remove dust cover/jounce bumper from strut mount insulator.
7. Gradually release spring compressor (commercial service tool), and remove coil spring.

ASSEMBLY

1. Compress coil spring using a spring compressor (commercial service tool), and install it onto the strut.

WARNING:

Make sure that the pawls of the two spring compressors are firmly hooked on the spring. The spring compressors must be tightened alternately so as not to tilt the spring.

CAUTION:

Face tube side of coil spring downward. Align lower end to spring seat as shown.

2. Install dust cover/jounce bumper to strut mount insulator.

CAUTION:

- Be sure to install dust cover/jounce bumper to strut mount insulator securely.
- When installing dust cover/jounce bumper, use soapy water. Do not use machine oil or other lubricants.

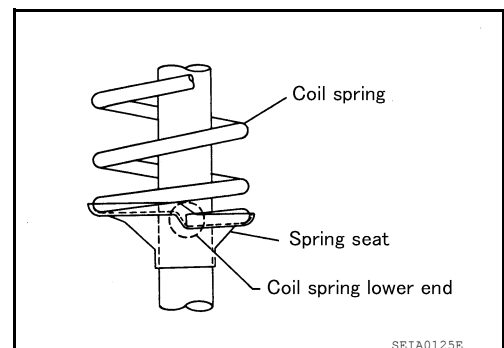

FRONT COIL SPRING AND STRUT

< UNIT DISASSEMBLY AND ASSEMBLY >

3. Install small parts to the strut.
 - Spring upper seat/strut bearing and strut mount insulator. Temporarily install piston rod lock nut.
4. Be sure tab (A) on strut mount insulator is positioned as shown.

A : Tab
⇐ : Vehicle front

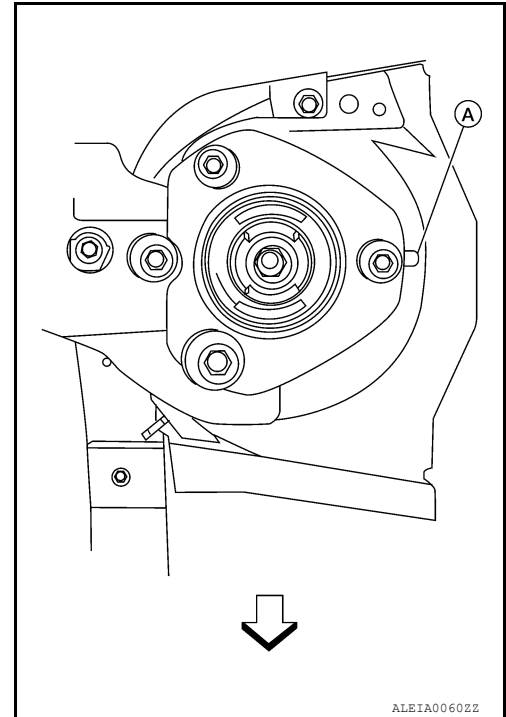

5. Be sure coil spring is properly set in spring rubber seat. Gradually release spring compressor.
 - CAUTION:**
Be sure upper rubber seat is properly aligned to spring upper seat and coil spring.
6. Tighten piston rod lock nut to the specified torque.
7. Remove Tool (A) from strut.

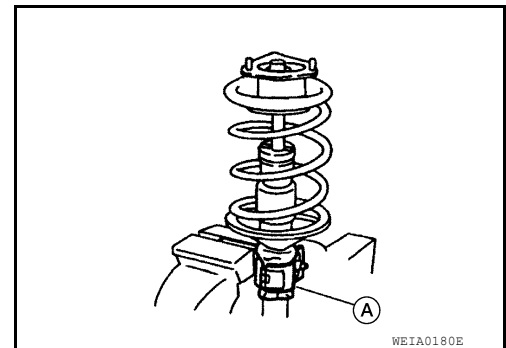

Inspection

INFOID:000000006236741

INSPECTION AFTER DISASSEMBLY

Strut

- Check strut for deformation, cracks, and damage, and replace if necessary.
- Check piston rod for damage, uneven wear, and distortion, and replace if necessary.
- Check welded and sealed areas for oil leakage, and replace if necessary.

Insulator and Rubber Parts

Check strut mount insulator for cracks and rubber parts for wear. Replace them if necessary.

Coil Spring

Check for cracks, wear, and damage, and replace if necessary.

SERVICE DATA AND SPECIFICATIONS (SDS)

< SERVICE DATA AND SPECIFICATIONS (SDS)

SERVICE DATA AND SPECIFICATIONS (SDS)

SERVICE DATA AND SPECIFICATIONS (SDS)

Wheel Alignment (Unladen*)

INFOID:000000006236742

Market			United States/Canada		Mexico	
Tire size			245/45R18	245/40R19	245/45R18	245/40R19
Camber Degree minute (Decimal degree)	LH	Minimum	-1°05' (-1.10°)	-1°10' (-1.15°)	-0°55' (-0.95°)	
		Nominal	-0°20' (-0.35°)	-0°25' (-0.40°)	-0°10' (-0.20°)	
		Maximum	0°25' (0.40°)	0°20' (0.35°)	0°35' (0.55°)	
	RH	Minimum	-1°20' (-1.35°)	-1°25' (-1.40°)	-1°10' (-1.20°)	
		Nominal	-0°35' (-0.60°)	-0°40' (-0.65°)	-0°25' (-0.45°)	
		Maximum	0°10' (0.15°)	0°05' (0.10°)	0°20' (0.30°)	
RH with respect to LH		0°15' ± 0°33' (0.25° ± 0.55°)				
Caster Degree minute (Decimal degree) Against ground surface	Minimum	4°10' (4.20°)		4°15' (4.25°)	3°45' (3.75°)	
	Nominal	4°55' (4.95°)		5°00' (5.00°)	4°30' (4.50°)	
	Maximum	5°40' (5.70°)		5°45' (5.75°)	5°15' (5.25°)	
	Maximum left and right difference	0°33' (0.55°)				
Kingpin offset Degree minute (Decimal degree)			14°25' (14.42°)		14°05' (14.10°)	

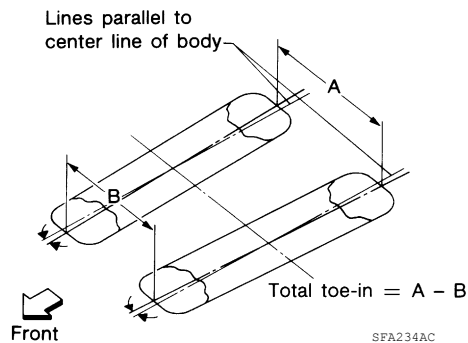

Total toe-in	Distance (A - B)	Minimum	0 mm (0.0 in)
		Nominal	1 mm (0.039 in)
		Maximum	2 mm (0.079 in)
	Angle (left or right, each side) Degree minute (Degree)	Minimum	0°00'(0.00°)
		Nominal	0°02'(0.03°)
		Maximum	0°00'(0.00°)
Wheel turning angle		Refer to ST-37, "Steering Angle"	

* : Fuel, radiator coolant and engine oil full. Spare tire, jack, hand tools and mats in designated positions.

Ball Joint

INFOID:000000006236743

Measurement on spring balance (cotter pinhole position)	7.94 - 53.97 N (0.81 - 5.50 kg, 1.79 - 12.2 lb)
Axial endplay	0.1 mm (0.004 in) or less

SERVICE DATA AND SPECIFICATIONS (SDS)

< SERVICE DATA AND SPECIFICATIONS (SDS)

Wheelarch Height (Unladen*1)

INFOID:000000006236744

Unit: mm (in)

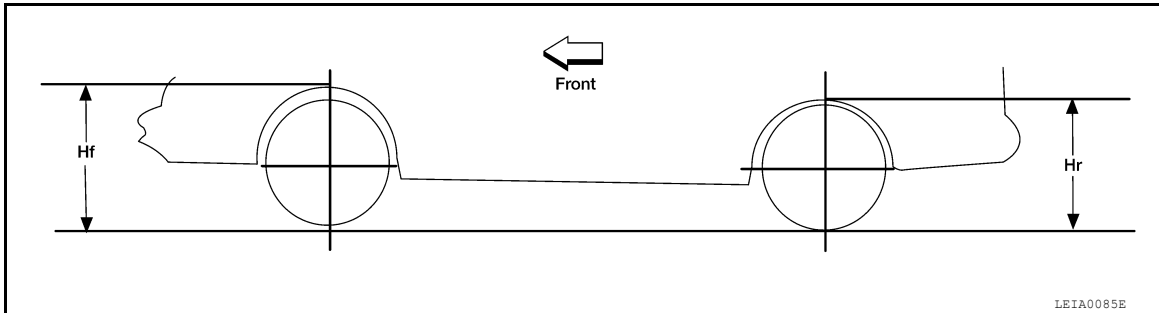

Market	United States			Canada			Mexico	
Tire size	P245/45R18*2	P245/45R18*3	P245/40R19*2	P245/45R18*2	P245/45R18*3	P245/40R19*2	P245/45R18*2	P245/40R19*2
Front (Hf)	719 (28.31)	719 (28.31)	723 (28.46)	720 (28.35)	719 (28.31)	723 (28.46)	729 (28.70)	732 (28.82)
Rear (Hr)	728 (28.66)	727 (28.62)	730 (28.74)	728 (28.66)	727 (28.62)	730 (28.74)	747 (29.41)	750 (29.53)

*1: Fuel, engine coolant and engine oil full. Spare tire, jack, hand tools and mats in designated positions.

*2: Without top load sunroof

*3: With top load sunroof